

International Standard



4766

---

INTERNATIONAL ORGANIZATION FOR STANDARDIZATION • МЕЖДУНАРОДНАЯ ОРГАНИЗАЦИЯ ПО СТАНДАРТИЗАЦИИ • ORGANISATION INTERNATIONALE DE NORMALISATION

---

**Slotted set screws with flat point**

*Vis sans tête, fendues, à bout plat*

First edition — 1983-09-01

---

UDC 621.882.219.4

Ref. No. ISO 4766-1983 (E)

Descriptors : fasteners, screws, slotted headless screws, dimensions, specifications, designation.

Price based on 3 pages

## Foreword

ISO (the International Organization for Standardization) is a worldwide federation of national standards bodies (ISO member bodies). The work of developing International Standards is carried out through ISO technical committees. Every member body interested in a subject for which a technical committee has been authorized has the right to be represented on that committee. International organizations, governmental and non-governmental, in liaison with ISO, also take part in the work.

Draft International Standards adopted by the technical committees are circulated to the member bodies for approval before their acceptance as International Standards by the ISO Council.

International Standard ISO 4766 was developed by Technical Committee ISO/TC 2, *Fasteners*, and was circulated to the member bodies in December 1981.

It has been approved by the member bodies of the following countries:

Austria	Germany, F.R.	New Zealand
Belgium	Hungary	Norway
Brazil	India	Poland
Canada	Ireland	Romania
China	Italy	South Africa, Rep. of
Czechoslovakia	Japan	Spain
Denmark	Korea, Dem. P. Rep. of	Sweden
Egypt, Arab Rep. of	Korea, Rep. of	Switzerland
Finland	Mexico	United Kingdom
France	Netherlands	USSR

No member body expressed disapproval of the document.

# Slotted set screws with flat point

## 1 Scope and field of application

This International Standard specifies the characteristics of slotted set screws with flat point and thread sizes from M 1,2 to M 12 inclusive and product grade A.

If other specifications are required, it is recommended that they should be selected from existing International Standards, for example ISO 261, ISO 888, ISO 898, ISO 965, ISO 3506.

## 2 References

ISO 225, *Fasteners — Bolts, screws, studs and nuts — Symbols and designations of dimensions.*

ISO 261, *ISO general purpose metric screw threads — General plan.*

ISO 888, *Bolts, screws and studs — Nominal lengths, and thread lengths for general purpose bolts.*

ISO 898, *Mechanical properties of fasteners.*

ISO 965, *ISO general purpose metric screw threads — Tolerances.*

ISO 3269, *Fasteners — Acceptance inspection.*<sup>1)</sup>

ISO 3506, *Corrosion-resistant stainless steel fasteners — Specifications.*

ISO 4042, *Threaded components — Electroplated coatings components.*<sup>1)</sup>

ISO 4753, *Fasteners — Ends of parts with external metric ISO thread.*

ISO 4759/1, *Tolerances for fasteners — Part 1: Bolts, screws and nuts with thread diameters > 1,6 and < 150 mm and product grades A, B and C.*

<sup>1)</sup> At present at the stage of draft.

3 Dimensions

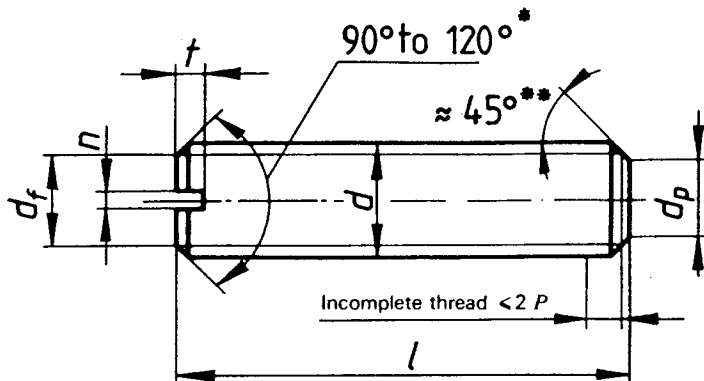

\* The 120° angle is mandatory for short length screws above the dotted stepped line.

\*\* The 45° angle applies only to the portion of the point below the root diameter of the thread.

Dimensions in millimetres

Thread size <i>d</i>	M 1,2	M 1,6	M 2	M 2,5	M 3	(M 3,5) <sup>1)</sup>	M 4	M 5	M 6	M 8	M 10	M 12	
<sup>2)</sup>	0,25	0,35	0,4	0,45	0,5	0,6	0,7	0,8	1	1,25	1,5	1,75	
<i>d<sub>f</sub></i>	Minor thread diameter												
<i>d<sub>p</sub></i>	max.												
	min.	0,35	0,55	0,75	1,25	1,75	1,95	2,25	3,2	3,7	5,2	6,64	8,14
	max.	0,6	0,8	1	1,5	2	2,2	2,5	3,5	4	5,5	7	8,5
<i>n</i>	nom.	0,2	0,25	0,25	0,4	0,4	0,5	0,6	0,8	1	1,2	1,6	2
	min.	0,26	0,31	0,31	0,46	0,46	0,56	0,66	0,86	1,06	1,26	1,66	2,06
	max.	0,4	0,45	0,45	0,6	0,6	0,7	0,8	1	1,2	1,51	1,91	2,31
<i>t</i>	min.	0,4	0,56	0,64	0,72	0,8	0,96	1,12	1,28	1,6	2	2,4	2,8
	max.	0,52	0,74	0,84	0,95	1,05	1,21	1,42	1,63	2	2,5	3	3,6
<sup>1), 3)</sup>													
	nom.	min.	max.										
	2	1,8	2,2										
	2,5	2,3	2,7										
	3	2,8	3,2										
	4	3,7	4,3										
	5	4,7	5,3										
	6	5,7	6,3										
	8	7,7	8,3										
	10	9,7	10,3										
	12	11,6	12,4										
	(14)	13,6	14,4										
	16	15,6	16,4										
	20	19,6	20,4										
	25	24,6	25,4										
	30	29,6	30,4										
	35	34,5	35,5										
	40	39,5	40,5										
	45	44,5	45,5										
	50	49,5	50,5										
	55	54,4	55,6										
	60	59,4	60,6										

- 1) Sizes in brackets should be avoided if possible.
- 2) *P* = pitch of the thread.
- 3) Min. and max. values according to ISO 4759/1, but rounded to one decimal place.

#### 4 Specifications and reference International Standards

Material		Steel	Stainless steel	Non-ferrous metal
Thread	Tolerance	6g		
	International Standards	ISO 261, ISO 965		
Mechanical properties	Property class	14H, 22H	A1 - 50	1)
	International Standards	ISO 898/5	ISO 3506	
Tolerances	Product grade	A		
	International Standard	ISO 4759/1		
Finish		Plain Requirements for electroplating are covered in ISO 4042. If different electroplating requirements are desired or if requirements are needed for other finishes, they should be negotiated between supplier and customer.		
Acceptability		The acceptance procedure is covered in ISO 3269.		

1) Will be covered in a future International Standard.

#### 5 Designation

Example for the designation of a slotted set screw with flat point, thread size  $d = M5$ , nominal length  $l = 12$  mm and property class 14H:

Set screw ISO 4766 - M5 × 12 - 14H